

- Safety and installation instructions

CAUTION! IMPORTANT INSTRUCTIONS: for personal safety it is important to read and follow these instructions, and store them in a safe place. In case of doubt, contact the Nice Support Service. Incorrect installation is a safety hazard and can lead to faulty operation.

Installation, hookup, programming and maintenance shall only be performed by qualified technicians, in compliance with the applicable laws, standards, local regulations and these instructions.

The transmitter component (TX) and the receiver component (RX) on the device shall be permanently installed opposite one another on two vertical and parallel walls. The walls shall be solid so they do not transmit any vibrations to the photocells.

The photocells shall be installed in a position that protects them from accidental impacts and that ensures easy access for maintenance.

The photocells must be connected only to a NICE control unit (or interface) equipped with “BlueBus” technology.

The photocell must operate only when an object is placed between the TX and the RX). Operation by reflection is prohibited.

To increase the level of safety against malfunction, the photocells shall be connected to a command control unit (or interface) equipped with the “phototest” function.

The product is protected against water and dust; it is therefore suited for normal outdoors applications. It is however not suited for use in heavily saline, acidic or potentially explosive atmospheres. Do not install the equipment in areas subject to flooding or water stagnation.

The electrical cables must enter the photocell through one of the holes located on the bottom of its mount and must be inserted from below . This so as to prevent water dripping inside the product.

2 - Product description and intended use This device is a photocell, namely a type-D presence detector, pursuant to the EN 12453 standard. It is part of the Era-EP series, and is intended to be used on automation systems for doors, gates, garage doors and similar installations.

Any use other than that described is to be considered improper and prohibited!

The device uses “BlueBus” technology, which enables the connection and communication among the photocells and the command control unit (or interface) with two wires.

This is a “parallel” connection. Each pair of photocells shall be assigned a specific task in the automation by the insertion of jumpers. The product may be used together with “FT210B” series devices, equipped with the “BlueBus” technology (see fig. 6 and 7), which enable the resolution of problem of electric connection with the sensitive edges installed on moving door leaves.

3 - Installation and connections

VERY IMPORTANT!

– So that there is optical alignment between the TX and the RX, make sure to check, prior to installation, that the walls where the photocells are to be mounted are parallel to one another.

If the walls are not parallel, it is suggested that adjustable photocells (e.g. EPLOB) be used, as the alignment of these photocells cannot be adjusted once their installation has been completed.

01. Prior to installation read the warnings in Chapter 1 and the data in Chapter 8.

02. Disassemble and prepare the photocells (fig. 1, 2, ,3, 4 and 5).

03.Consult the instruction manual for your control unit (or interface) (or fig. 6,7,8,9 and 10) to choose the detection function and the corresponding installation position, that are to be assigned to the pair of photocells. Note their identification code number (e.g. “PHOTO 2”). To use one or two pairs of photocells as the automatic opening control device, choose either the

FA1 and/or the FA2 functions.

04. Identify the identification code number chosen previously in Table A (e.g. "PHOTO 2"). Note the diagram found under the code number and insert the jumpers in the TX and RX photocells, in the same position as shown in the diagram. Note – Keep any unused jumpers for any possible future need (fig. 11).

05. If other pairs of photocells are to be installed, repeat points 03 and 04 for each.

Caution! – Each pair of photocells must use a different jumper configuration than that used for the other photocells in the automation.

06. Attach the photocell brackets to the walls in the pre-established locations.

Caution! The two elements must be aligned on a single axis (fig. 12-a), to facilitate the subsequent optical aiming of the TX to the RX. If the walls do not facilitate this alignment, it is suggested that, at this point, the photocell brackets be installed provisionally (using adhesive tape or other method), to then install them definitively (fig. 12-b) only once testing has been completed (Chapter 4).

Note – Only for single or double leaf sliding gates – To avoid interference among the different "Blue Bus" devices, position the TX and RX components as indicated on the tags in fig. 6 or 7

07. Disconnect the power from the automation and if present, disconnect the back-up battery.

08. Connect the TX and RX components in "parallel" (fig. 13) using a two-wire bus cable.

Then, connect the bus cable to the "BlueBus" terminal on the control unit (or interface). Matching polarity is not required.

09. Photocells used as the "automatic opening control device" – If the photocells are set up for this function (check in point 03), complete their installation by cutting the electrical bridge between points "A", on the TX and RX circuit cards (fig. 14).

10. Install the TX and RX modules on their supports (fig. 15).

11. Power the automation and perform the "BlueBus device learning procedure", found in the control unit (or interface) instruction manual.

Note – If this photocell is going to be used to replace a previously existing photocell, the jumpers must be positioned in the same manner as before. In this case the device learning procedure is not required.

12. Perform the test procedure as described in Chapter 4.

13. Complete the installation as shown in fig. 18, 19. 4 - Automation Testing To make sure that the photocells are operating properly or to detect any interference from other devices, take these steps.

01. Power the automation and observe the status of the LEDs on the TX and RX (fig. 15). Use Table B to find out the meaning of the different statuses, keeping in mind that proper operation is indicated only when the two LEDs flash very slowly . If the status is not compliant, perform the operations provided for in Table B. In particular, if the alignment between TX and RX requires adjustment, move one or both the photocells until they are aimed at one another; that is, once the two LEDs flash very slowly (= optimum reciprocal alignment).

02. Check their operation by blocking the line of sight between them with a cylinder ($\varnothing = 5$ cm; L = 30 cm): first pass the object close to the TX, then to the RX and, finally, halfway between them (fig. 16). Make sure that in each case the output switches from "Active" to "Alarm" and back, and that the automation responds properly to actuation of the photocell.

03. Verify the correct obstacle detection as required by the EN 12445 standard, using a parallelepiped (700 x 300 x 200 mm) with three faces (one per dimension) with a matt black surface and the others with glossy reflective surface (fig. 17). Caution! – After having added, removed or replaced any automation photocells, the entire automation system must be tested, referring to the manuals for each of the different devices.

5 - User warnings

Caution! – Photocells do not constitute actual safety devices, but are rather safety aids. Although constructed for maximum reliability, in extreme conditions they may malfunction or fail, and this may not be immediately evident. For this

reason, and as a matter of good practice, observe the following instructions: • Transit can only occur if the gate or door are completely open and with the leaves stationary. • NEVER TRANSIT while the gate or door are closing or are about to close. • If you note any sign of malfunction, shut off power to the automation immediately and use manual mode only (refer to the automation instruction manual). Contact your maintenance staff/person for the control and the possible repair.

6 - Maintenance Service the photocells at least every 6 months as follows:

- 1.) Release the motor as instructed in the user manual to prevent the automation operating unexpectedly during maintenance;
- 2) check for humidity, oxidation and foreign bodies (such as insects) and remove them. In case of doubt, replace the equipment;
- 3) clean the housing – especially the lenses and glass panels – with a soft, slightly damp cloth. Do not use alcohol, benzene, abrasive or other cleaning products; these can affect the polished surfaces and compromise the operation of the photocells;
- 4) run the tests indicated in “Tests”;
- 5) the product is designed to work for at least 10 years in normal conditions; we recommend increasing the frequency of maintenance thereafter.

7 - Scrapping

This product is an integral part of the automation and must therefore be scrapped together with it, in the same way as indicated in the automation’s instruction manual.

8 - Technical specifications

Please note: the technical features refer to an ambient temperature of 20°C. Nice S.p.a. reserves the right to modify the products without altering their intended use and essential functions.

Type of product:

presence detector for automated gates and doors (type D per EN 12453).

Technology adopted:

direct optical interpolation between TX and RX units, with modulated IR beam.

Power supply / output:

The device may be connected only to a control unit (or interface) equipped with “BlueBus” technology. The electrical power is drawn from this device, where the output signals are sent.

Maximum absorbed power: 1 “BlueBus” unit.

TX beam angle: 20° (± 25%).

RX field angle: 8° (± 25%).

Range: useful range 15m; maximum range 30m. The range may be reduced by 50% in poor atmospheric conditions (fog, rain, dust, etc.).

Detection capacity:

opaque objects larger than 50 mm along the line of sight between TX and RX (max. speed 1.6 m/s).

Number of photocells that may be connected: Up to 7 pairs of safety function photocells may be installed and 2 pairs to control the open command (automatic synchronisation avoids interference among the different detectors).

Maximum length of the wire: all components must be connected in parallel. The sum of the lengths of all of the wires used to connect the different components, including the wire coming from the control unit shall not be greater than 50 metres.

Protection rating: IP 44

Use in acid, saline or potentially explosive atmosphere: no.

Operating temperature: -20 to +50°C

Installation: elements installed facing each other on two vertical parallel walls, or on an appropriate column support.

TX/RX alignment adjustment: no.

Dimensions (single component) / Weight (sum of two components):

–
EPLB - EPLB/A
, 70 x 70(h) x 30 mm / 165 g –

EPMB
- EPMB/A
, 50 x 80(h) x 28.5 mm / 143 g

9 - CE Declaration of Conformity

Nice S.p.A. hereby declares that the products: EPLB ,EPMB comply with the essential requirements and other pertinent provisions defined by Directive 2004/108/

EC . The CE declaration of conformity can be viewed and printed at the website www.nice-service.com, or may be requested directly from Nice S.p.A. Mr. Mauro Sordini (Chief Executive Officer)

Table B • Tabella B • Tableau B			
EN	LED STATUS	MEANING	ACTION
	Always off	TX, RX - The photocell has no power supply or is faulty.	Check that on the terminals of the photocell there is a voltage of approximately 8 to 12 V DC. If the voltage is correct, it is likely that the photocell is faulty
	3 quick flashes, (pause), ...	(TX,RX) - The pair of photocells has not been memorised in the control unit (or the interface).	Make sure that each pair of photocells has a different jumper configuration than the others. Perform the device learning procedure (Chapter 3, point 11).
	Very slow flashing	(TX, RX) - The TX is transmitting properly. The RX is receiving an optimum signal.	None; optimum TX - RX alignment.
	Slow flashing	(RX) - The RX is receiving a <u>good signal</u> .	None; good operation.
	Fast flashing	(RX) - The RX is receiving a <u>weak signal</u> .	Fair operation; the photocell glass should be cleaned.
	Very fast flashing	(RX) - The RX is receiving a <u>poor signal</u> .	Barely operational; clean the photocell glass and realign the TX and RX photocells.
	Always on	(TX, RX) -The RX is receiving <u>no signal</u> .	Check if there is an obstacle between the TX and the RX; clean the photocell glass and realign the TX and RX photocells.

Table A									
Photocells positions	FOTO	FOTO II	FOTO 1	FOTO 1 II	FOTO 2	FOTO 2 II	FOTO 3	FA1(*)	FA2(*)
Jumpers positions									

(*) • EN – Cut the electrical bridge "A" on the TX and RX wiring diagram (fig. 14).

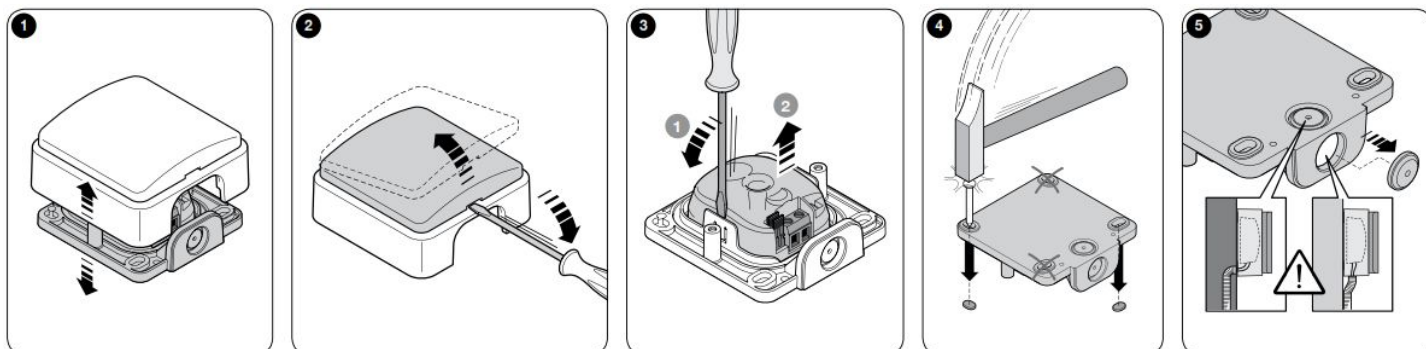

6

• EN - Single leaf sliding gate • IT - Cancello scorrevole ad anta singola • FR - Portail coulissant à un seul vantail • ES - Puerta de corredera de una hoja • DE - Einteiliges Schiebetor • PL - Brama przesuwana z jednym skrzydłem • NL - Schuifpoort met enkele vleugel

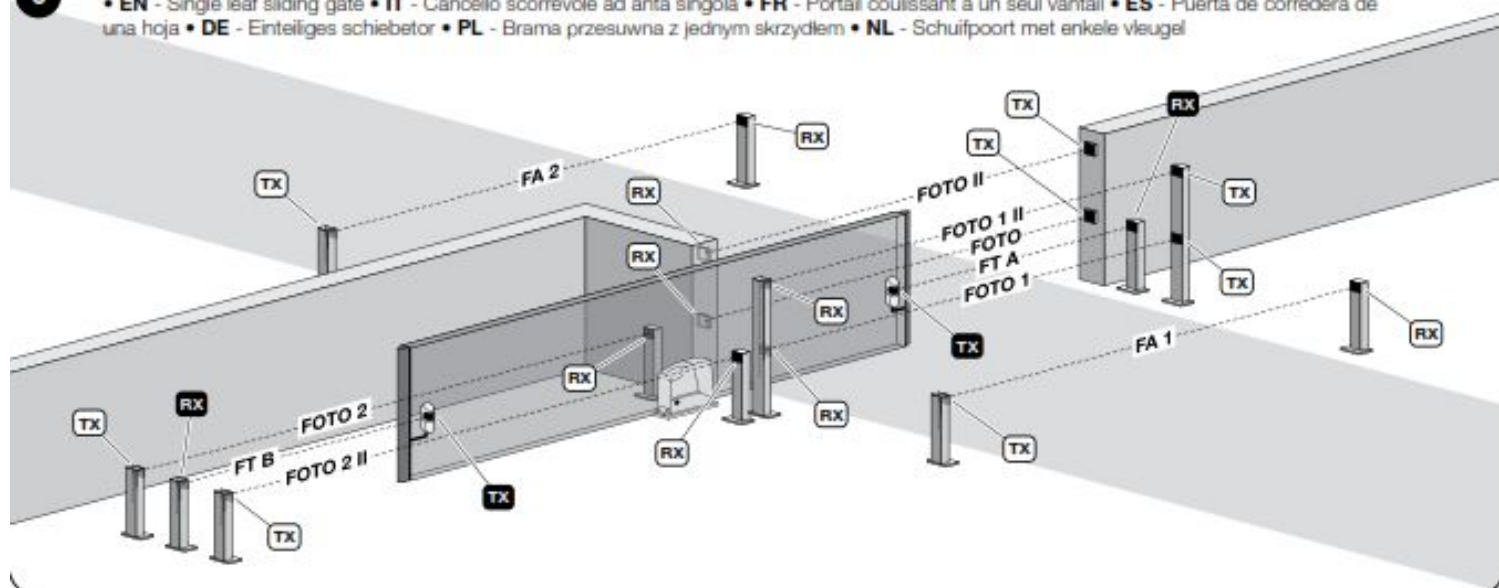

7

• EN - Synchronised leaves sliding gate • IT - Cancello scorrevole ad ante contrapposte • FR - Portail coulissant à vantaux opposés • ES - Puerta de corredera de hojas contrapuestas • DE - Schiebetor mit entgegengesetzt angebrachten Torflügeln • PL - Brama przesuwana z dwoma przeciwniezącymi skrzydłami • NL - Schuifpoort met tegengestelde vleugels

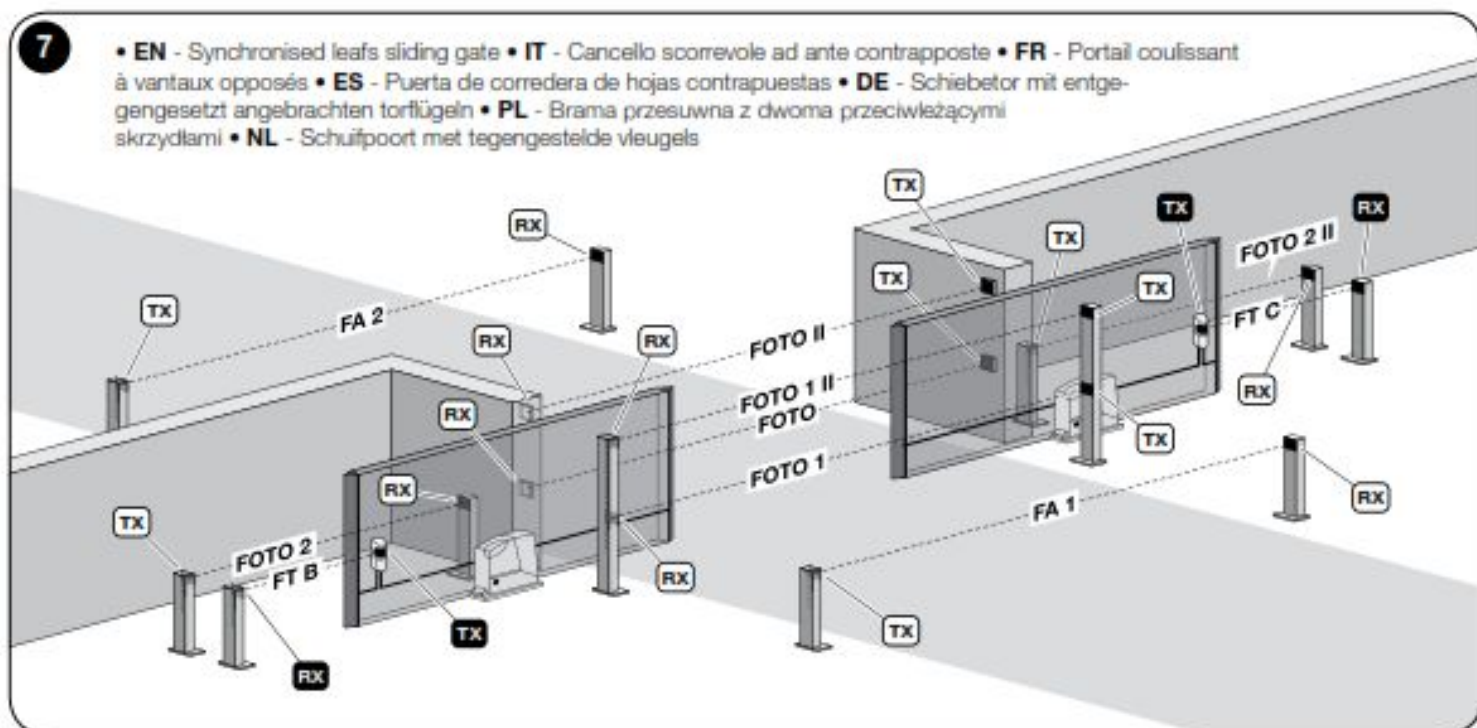

8

• EN - Swing gate • IT - Cancello a battente • FR - Portail battant • ES - Puerta de batiente • DE - Drehtor • PL - Brama skrzydłowa • NL - Kanteldeur voor garage

